

HPS40000TL/HPS50000TL

40-50kW three phase all-in-one hybrid inverter for small commercial use.

Features

-  All-in-one hybrid inverter
-  ATS function inbuilt
-  IP65 waterproof design
-  Seamless on/off grid transfer within 10 ms
-  Max. 10 units in parallel for on&off grid operation
-  Support remote control of DG
-  Programmable working mode
-  Multiple MPPT inputs



Block Diagram

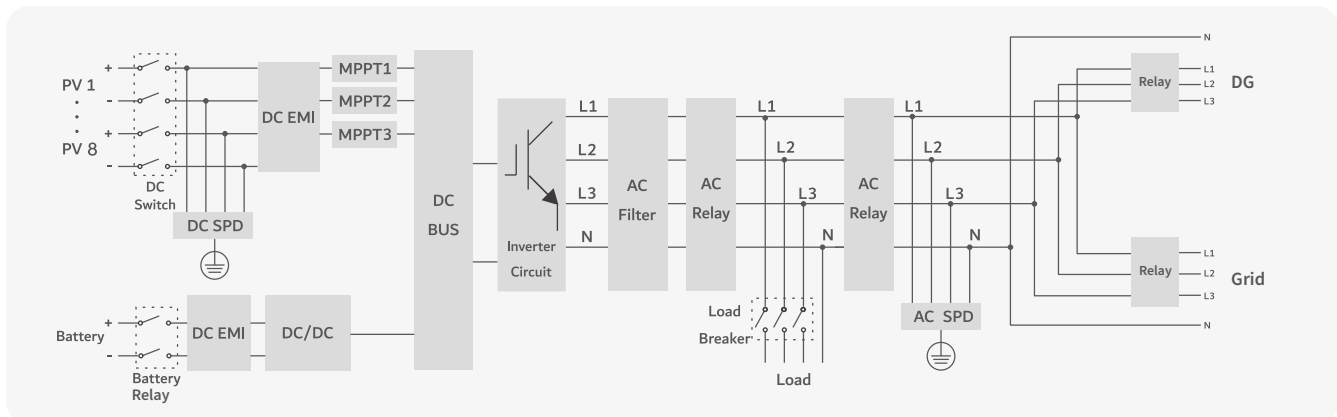

HPS40000TL**HPS50000TL****AC(on-grid)**

Apparent power	44kVA	55kVA
Rated power	40kW	50kW
Rated voltage	400V	400V
Rated current	57A	72A
Voltage range	360V-440V	360V-440V
Rated frequency	50/60Hz	50/60Hz
Frequency range	45~55/55~65Hz	45~55/55~65Hz
THDI	<3%	<3%
PF	0.8 lagging~0.8 leading	0.8 lagging~0.8 leading
AC connection	3L/N/PE	3L/N/PE
Max. AC Input Power	60kW	70kW

AC(off-grid)

Apparent power	44kVA	55kVA
Rated power	40kW	50kW
Rated voltage	400V	400V
Rated current	57A	72A
THDU	≤2% linear	≤2% linear
Rated frequency	50/60Hz	50/60Hz
Overload capability	110%-10 mins 120%-1 min, 150%-10s	110%-10 mins 120%-1 min, 150%-10s

DC (Battery and PV)

Max. PV Open-circuit voltage	1000V	1000V
Max. PV access power	80kWp	100kWp
Max. PV input power	60kWp	75kWp
PV MPPT voltage range	125V-850V	125V-850V
Number of MPPT	3	3
PV input/MPPT	2/3/3	2/3/3
PV input current	40/60/60A	40/60/60A
Max. PV Isc	60/90/90A	60/90/90A
Max. PV Isc/Channel	20A	20A
Battery voltage range	150-800V	150-800V
Full load battery voltage range	430-800V	500-800V
Max. charge/discharge power	40kW	50kW
Max. charge/discharge current	100A	100A

General Information

Protection devices	PV DC switch, PV fuse, battery breaker and fuse
Protection degree	IP65
AFCI function	Optional
Noise emission	<65dB(A)@1m
Operating temperature	-40 °C~+60 °C
Cooling method	Intelligent air cooling
Relative humidity	0-100% non-condensing
Max. altitude	5000m (derate over 3000m)
Dimension (W/H/D)	600/990/280mm
Weight	90kg
Topology	Transformerless
Lightning protection	Type II
Transfer between on/off grid	Automatic≤10ms
Standby consumption	<20W

Communication

Display	Touch screen
Communication	RS485/CAN

Certificate

CE , EN IEC 61000-6-4:2019 , EN 61000-3-12:2011 , EN IEC 61000-3-11:2019 , EN IEC 61000-6-2:2019 , EN62109-1:2010 , EN62109-2:2011 , NRS097-2-1:2017 , AS4777.2