

# SMC200 SMC200HV

Smart MPPT controller, used together with ATESS PCS for large scale solar projects.

## Features



Modular design



Up to 8 MPPTs



Transformerless design



Multiple units parallelable



## Block Diagram

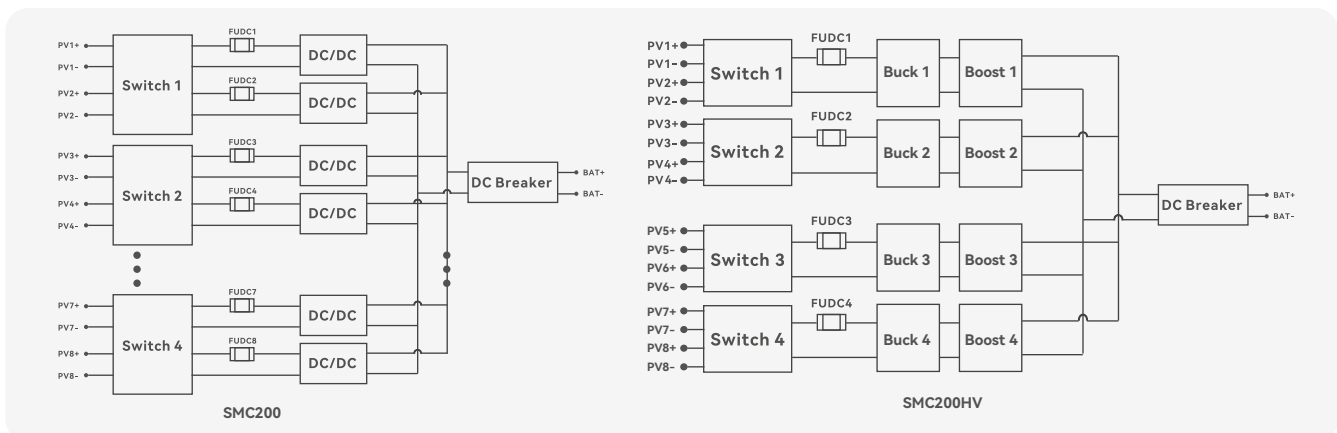

Note: The final configuration depends on the actual PV module parameters or project plan.

	SMC200	SMC200HV
<b>Input(PV)</b>		
Max. PV power	200kW	200kW
Rated PV power	180kW	180kW
MPPT voltage range	900V-1300V	900V-1500V
Max. input current	160A(20A*8)	160A(20A*8)
Number of MPPT	8	4

<b>Output (Battery and PCS)</b>		
Output voltage	600V-900V(700V-900V full load)	900V-1500V(1250V-1500V full load)
Max. charge power	180kW	200kW
Max. charge current	280A	160A
Max. charge efficiency	99%	98%
Battery type	Lead-acid or lithium-ion	Lead-acid or lithium-ion

<b>Protection</b>		
Input & output OV/UV protection	Yes	Yes
Input & output OC protection	Yes	Yes
Short circuit protection	Yes	Yes
Over temperature protection	Yes	Yes
Lightning protection	Type II	Type II
DC breaker	Yes	Yes
Emergency stop	Yes	Yes

<b>General Information</b>		
Protection degree	IP65	IP65
Noise emission	<65dB(A)@1m	<65dB(A)@1m
Operating temperature	-25 °C~+55 °C	-25 °C~+55 °C
Cooling method	Intelligent fan cooling	Intelligent fan cooling
Relative humidity	0-95% non-condensing	0-95% non-condensing
Max. altitude	6000m (derate over 3000m)	6000m (derate over 3000m)
Dimension (W/H/D)	780/770/210 mm	890/660/210 mm
Weight	65kg	68kg
Topology	Transformerless	Transformerless
Standby power	<100W	<100W

<b>Communication</b>		
Communication	RS485/CAN	RS485/CAN