

# PCS100/250/500-US-480 PCS630/1000-US-480

Bidirectional battery inverter from 100kW to 1000kW, can be used alone or with solar charge controllers and other accessories for different application scenarios.

## Features

- Programmable working mode
- Flexible configuration
- Touchscreen LCD
- Support remote control of DG
- Max. 8 units in parallel for on&off grid operation



## Block Diagram

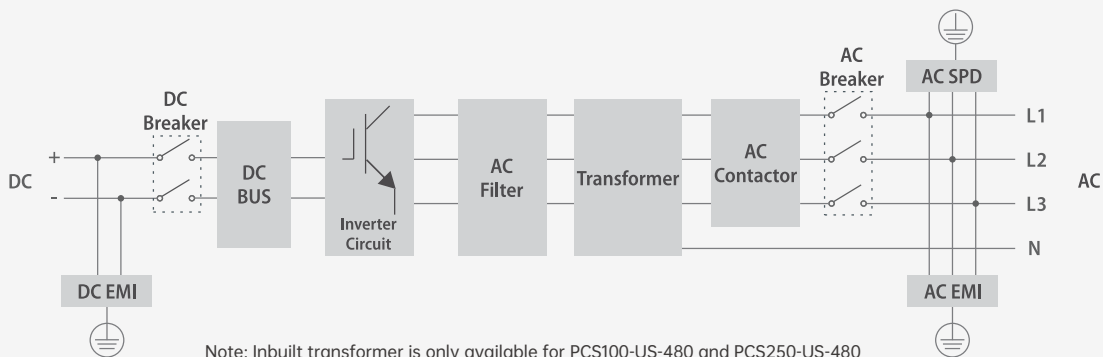

**PCS100-US-480      PCS250-US-480      PCS500-US-480      PCS630-US-480      PCS1000-US-480**

<b>AC(on-grid)</b>					
Apparent power	100kVA	250kVA	500kVA	630kVA	1000kVA
Rated power	100kW	250kW	500kW	630kW	1000kW
Rated voltage	480V	480V	480V	480V	480V
Rated current	120A	301A	601A	758A	1203A
Voltage range	432V-528V	432V-528V	432V-528V	432V-528V	432V-528V
Rated frequency	50/60Hz	50/60Hz	50/60Hz	50/60Hz	50/60Hz
Frequency range	45~55/55~65Hz	45~55/55~65Hz	45~55/55~65Hz	45~55/55~65Hz	47-51.5/57-61.5Hz
THDI	<3%	<3%	<3%	<3%	<3%
PF	0.8 lagging~0.8 leading	0.8 lagging~0.8 leading	0.8 lagging~0.8 leading	0.8 lagging~0.8 leading	0.8 lagging~0.8 leading
AC connection	3/N/PE	3/N/PE	3/PE	3/PE	3/PE

<b>AC(off-grid)</b>					
Apparent power	100kVA	250kVA	500kVA	630kVA	1000kVA
Rated power	100kW	250kW	500kW	630kW	1000kW
Rated voltage	480V	480V	480V	480V	480V
Rated current	120A	301A	601A	758A	1203A
THDU	≤2% linear	≤2% linear	≤2% linear	≤2% linear	≤2% linear
Rated frequency	50/60Hz	50/60Hz	50/60Hz	50/60Hz	50/60Hz
Overload capability	110%-10 mins 120%-1 min	110%-10 mins 120%-1 min	110%-10 mins 120%-1 min	110%-10 mins 120%-1 min	110%-10 mins 120%-1 min

<b>DC (Battery and PV)</b>					
Rated power	100kW	250kW	500kW	630kW	1000kW
Current regulation	±1%	±1%	±1%	±1%	±1%
Voltage regulation	±1%	±1%	±1%	±1%	±1%
Voltage ripple	<3%	<3%	<3%	<3%	<3%
Current ripple	<2%	<2%	<2%	<2%	<2%
Voltage range	500V-820V	500V-820V	600V-900V	650V-900V	700V-900V
Max. charge/ discharge current	220A	550A	917A	1155A	1430A

<b>General Information</b>					
Max. efficiency	97.10%	97.30%	98.50%	98.50%	99.0%
Protection degree	Type 1	Type 1	Type 1	Type 1	Type 1
Noise emission	<65dB(A)@1m	<65dB(A)@1m	<65dB(A)@1m	<65dB(A)@1m	<65dB(A)@1m
Operating temperature	-25°C~+55°C	-25°C~+55°C	-25°C~+55°C	-25°C~+55°C	-25°C~+55°C
Cooling method	Forced-air	Forced-air	Forced-air	Forced-air	Forced-air
Relative humidity	0-95% non-condensing	0-95% non-condensing	0-95% non-condensing	0-95% non-condensing	0-95% non-condensing
Max. altitude	6000m (derate above 3000m)	6000m (derate above 3000m)	6000m (derate above 3000m)	6000m (derate above 3000m)	6000m (derate over 3000m)
Dimension(W/H/D)	1100/1890/850mm	1600/2080/850mm	1200/1900/800mm	1200/1900/800mm	1510/1900/850mm
Weight	820kg	1465kg	870kg	900kg	1500kg
Build-in transformer	Yes	Yes	No	No	No
Lightning protection	Type II	Type II	Type II	Type II	Type II
Transfer between on/off grid	Manual(default) Automatic(optional) ≤10ms	Manual(default) Automatic(optional) ≤10ms	Manual(default) Automatic(optional) ≤10ms	Manual(default) Automatic(optional) ≤10ms	Manual(default) Automatic(optional) ≤10ms

<b>Communication</b>					
Display	Touch screen	Touch screen	Touch screen	Touch screen	Touch screen
Communication	RS485/CAN	RS485/CAN	RS485/CAN	RS485/CAN	RS485/CAN

<b>Certificate</b>					
UL1741 , CSA-C22.2					