

ATESS SMC200







LEADING - EDGE TECHNOLOGY

Overview

Smart MPPT controller, used together with ATESS PCS and Bypass for large scale solar projects.

Features

-  Multiple units parallelable
-  Modular design
-  Up to 8 MPPTs
-  Transformerless design

Block Diagram

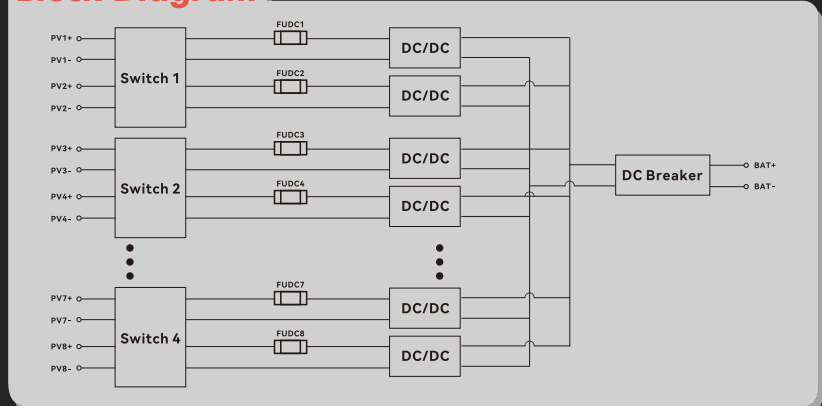

Datasheet

SMC200

Input (PV)

Max. PV power	200kW
MPPT voltage range	900V-1300V
Max. input current	160A(20A*8)
Number of MPPT	8

Output (Battery and PCS)

Output voltage	600V-900V(700V-900Vfull load)
Max. charge power	200kW
Max. charge current	280A
Max. charge efficiency	99%
Battery type	Lead-acid or lithium-ion

Protection

Input & output OV/UV protection	Yes
Input & output OC protection	Yes
Short circuit protection	Yes
Over temperature protection	Yes
Lightning protection	Type II
DC breaker	Yes
Emergency stop	Yes

General Information

Protection degree	IP65
Noise emission	<65dB(A)@1m
Operating temperature	-25 °C~+55 °C
Cooling method	Intelligent fan cooling
Relative humidity	0-95% non-condensing
Max. altitude	6000m (derate over 3000m)
Dimension (W/H/D)	780/770/210 mm
Weight	65kg
Topology	Transformerless
Standby power	<100W

Communication

RS485/CAN