

# ATS50/100/150-US-480

The ATS is an accessory of the HPS. When both the grid and DG need to access the HPS, the ATS will be used to switch between the grid and DG automatically.

## Features

-  HPS compatible
-  Flexible management
-  Transfer automatically between grid and DG
-  Support remote control of DG



## Block Diagram

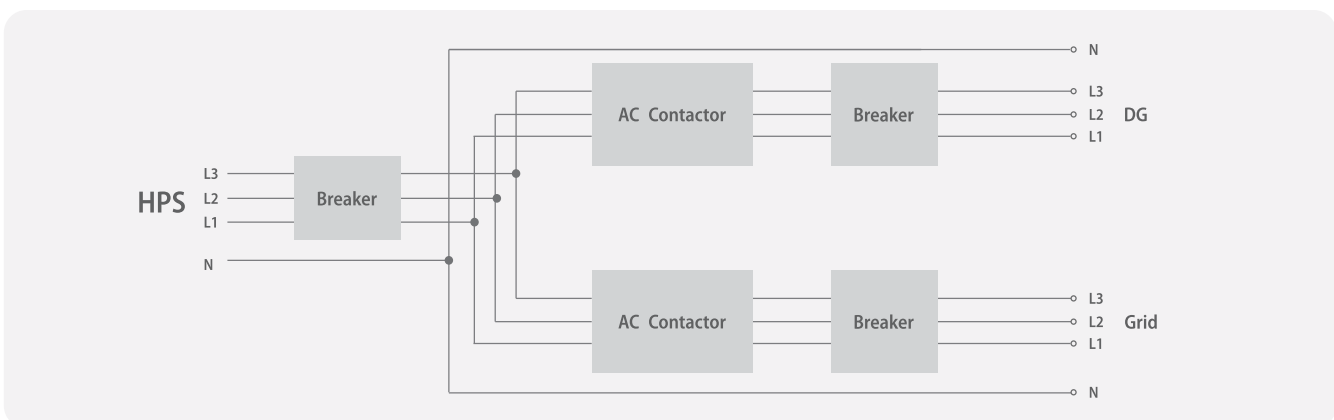

	ATS50-US-480	ATS100-US-480	ATS150-US-480
Rated voltage	480V	480V	480V
Rated current	120A	240A	288A
Rated frequency	50/60Hz	50/60Hz	50/60Hz
Rated power	100kVA	200kVA	240kVA
Output breaker	250A	400A	630A
Grid breaker	250A	400A	630A
DG breaker	250A	400A	630A
Lightning protection	Type II	Type II	Type II
Protection degree	Type 1	Type 1	Type 1
Relative humidity	0~95% non-condensing	0~95% non-condensing	0~95% non-condensing
Operating temperature	-25°C~+55°C	-25°C~+55°C	-25°C~+55°C
Dimension (W/H/D)	600/1500/450mm	700/1650/500mm	700/1650/500mm
Weight	77kg	125kg	125kg
Communication	RS485/CAN	RS485/CAN	RS485/CAN

---