

How to configure lithium battery for an ESS system

1. Overview

As we all know, energy storage battery plays an important role in an ESS system. Its main function is to store the energy generated by PV system, and supply load in the case of insufficient sun irradiation, grid cut-off or some other emergencies. Therefore, the battery is an indispensable part in a solar storage system. The commonly used storage batteries are lead-acid batteries, alkaline batteries, lithium batteries, ultracapacitor etc. At present, lithium batteries occupy the largest market share, among which the most common type is lithium iron phosphate(LFP) batteries. This paper emphasizes on the LFP battery and its application in energy storage system.

1.1 Working principle, basic structure and classification of battery

Lithium-ion battery is a kind of rechargeable battery, with main advantages of light weight, high energy density, high power, no pollution, long lifespan, small self discharge coefficient and wide range of temperature adaptation.

The existing types of lithium batteries are:

- Lithium iron phosphate (LFP) battery
- Three element lithium battery (NCM / NCA) battery
- Lithium cobalt oxide (LCO) battery
- Other lithium batteries, such as lithium manganate, lithium titanate, etc

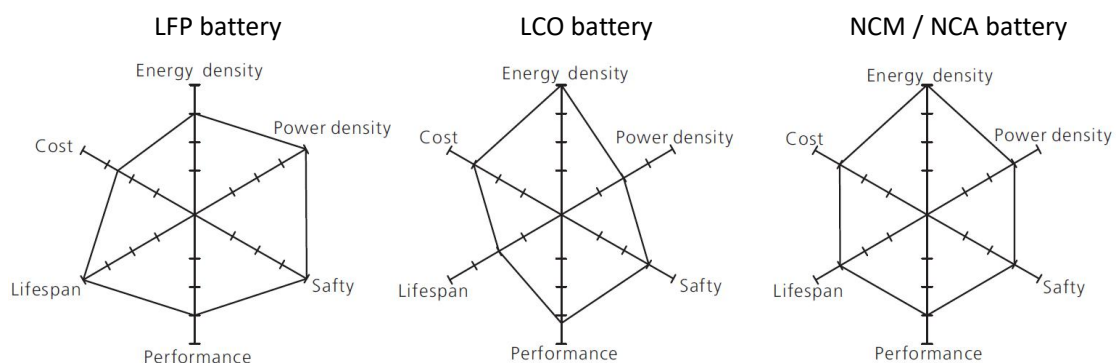

Fig.1-Performance of three different battery types

Energy density: The output energy of the battery per unit weight or volume. Unit is Wh.kg⁻¹ or wh.l⁻¹.

Power density: This is the specific energy of the battery per unit time. It indicates the working current that the battery can bear. If the power is large, a larger current can be used to discharge.

From the above parameters, we can see that except the energy density, other performance of LFP battery are obviously superior, which determines its dominant position in energy storage.

1.2 Definitions

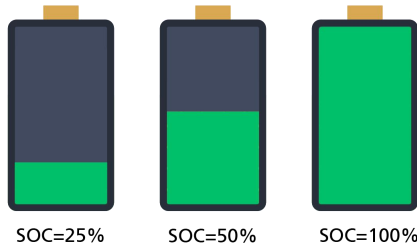
Noun	Unit	Definition
Ampere hour	Ah	Indicator of battery capacity. The electric capacity $wh = \text{power } W * \text{hour } H = \text{voltage } V * \text{ampere hour } ah$.
Ratio	C	It is used to express the ratio of battery charging and discharging current. Charging and discharging ratio = charging and discharging current / rated capacity. A measure of how fast or slow a battery is discharged. Generally, the capacity of the battery can be detected by different discharge currents. For example, when a battery with a capacity of 100Ah is discharged with 15A, its discharge rate is 0.15C.
DOD (depth of discharge)	%	It refers to the percentage of the discharged capacity of the battery and the rated capacity of the battery during the use of the battery. For the same battery, the depth of DOD set is inversely proportional to the cycle life of the battery.
SOC (state of charge)	%	It is the ratio of the performance parameters to the nominal parameters after the battery is used for a period of time. The newly manufactured battery is 100% and the total scrap is 0%. According to IEEE standard, after the battery is used for a period of time, the capacity when the battery is fully charged is less than 80% of the rated capacity, and the battery should be replaced.  <p style="text-align: center;">SOC=25% SOC=50% SOC=100%</p>
BMS(Battery Management System)		For battery condition monitoring, battery balance management, battery security and data communication.

Tab.1-definitions of commonly used battery indicators



2. How to configure ESS system with ATESS battery

2.1 ATESS LFP battery cell technical specification

Category	Parameter	Data
Nominal parameters	Nominal voltage (V)	3.2
	Nominal capacity (Ah)	100
Structural parameters	Dimension w * h * D (mm)	135*250*27
	Weight (kg)	1.97±0.03
Electrical parameters	Discharge voltage (V)	2.5
	Charging voltage (V)	3.65
	Maximum discharge current (A)	100 (1C)
	Rated discharge current (A)	50 (0.5C)
	Maximum charging current (A)	100 (1C)
	Rated charging current (A)	50 (0.5C)
Other parameters	Working temperature (°C)	-25~55
	communication interface	CAN
	Lifespan	>6000 (80%DOD)

Tab.2-specification of ATESS LFP battery

The ATESS battery module is combination of series and parallel connection of battery cells.



Fig.2-ATESS battery module



Our module configuration is 12S2P and 24S1P, specification is shown as below:

Battery module specification

Configuration	24S1P	12S2P
Rated capacity	100Ah	200Ah
Rated energy	7.68kWh	7.68kWh
Rated voltage	76.8V	38.4V
Voltage range	67.2-87.6V	33.6-43.8V
Nominal charge/discharge	0.5C	0.5C
Max charge/discharge	1C	1C
AC internal resistance	≤15mΩ	≤10mΩ
Dimension (W/H/D)mm	360/300/515	360/300/515
Weight	≤65kg	≤65kg

BMS parameters on LCD

Cell voltage	Yes	Yes
Cell high voltage	Yes	Yes
Cell low voltage	Yes	Yes
Cell temperature	Yes	Yes
Charge and discharge current	Yes	Yes
Total battery voltage	Yes	Yes
Battery SOC	Yes	Yes
Fault warning	Yes	Yes



Protection

Short circuit protection	Yes	Yes
Over current protection	Yes	Yes
Over charge protection	Yes	Yes
Over discharge protection	Yes	Yes
Cell over voltage protection	Yes	Yes
Cell under voltage protection	Yes	Yes
Over temperature protection	Yes	Yes

Fig.3-Specification for ATESS battery module

2.2 Choose inverter model

Model	Allowable battery voltage range
HPS5-10KTLS / HPS7.5-10LTL	280V-700V (85V-500V for HPS5000TLS)
HPS30-150	352V-600V
PCS50-250	500V-820V
PCS500-630	600V-900V

Configure the battery according

to ATESS models:

Tab.3-Battery voltage corresponding to each inverter model

Above is the battery voltage requirements of the ATESS inverter series products. After selecting the inverter model, we can choose one of the two existing modules (12s2p or 24s1p), then configure the modules in series and parallel and adapt the voltage of corresponding models. In addition, the battery voltage is also related to the PV voltage. The battery voltage and the inverter model are not the only factors we need to consider, because PV will be charging the battery, so the MPPT voltage must not be lower than the battery voltage.

For HPS5-10K series inverters, the PV to battery circuit of this type of inverter is BOOST circuit, so the relation between PV voltage and battery voltage can be ignored when configuring PV voltage;

Regarding the HPS30-150 series inverter, the PV to battery circuit of this type of inverter is a BUCK circuit, so when configuring the PV voltage, the MPPT voltage should be at least 50V higher than the battery voltage;



As to PCS series inverters, PBD250 and PBD350 shall be added when PV is configured for these models, in which PBD250 is with BOOST circuit and PBD350 is with BUCK circuit. Therefore, when PV voltage is configured for PBD250, the maximum open circuit voltage of PV shall be less than the minimum voltage of the battery. When PV voltage is configured for PBD350, MPPT voltage shall be configured at least 50V higher than the battery voltage.

2.3 Calculate battery capacity

In practical application, considering that each customer's demand for battery capacity is different, ATESS can customize the most suitable battery capacity for customers. The capacity of two existing modules of ATESS is 7.68kwh. Suppose that the current battery capacity required by the customer is α , and the number of battery modules required is $\beta = \frac{\alpha}{7.68}$, then we can split the number of modules β or put in series and parallel.

In terms of calculating the system battery capacity, due to process loss, battery discharge capacity is less than storage capacity, and load consumption is less than discharge capacity. Neglecting efficiency loss would likely to cause insufficient battery power supply.

When charging, battery charging efficiency and DC cable efficiency shall be considered. When discharging, battery discharge efficiency, inverter efficiency, load end efficiency, DC cable and AC cable efficiency shall be considered.

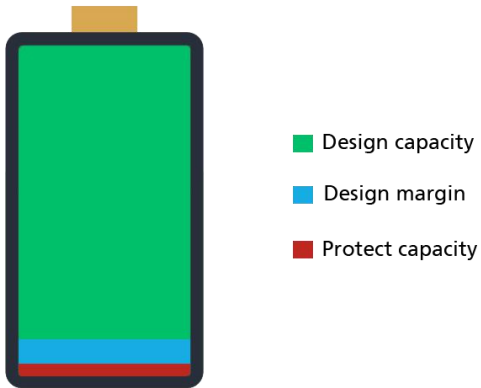

Fig.4-Battery capacity

2.4 Decide installation solution

After the battery is purchased, the installation layout is also a problem that the customer concerned about.



There are three options for the battery installation: battery rack, battery cabinet and container:

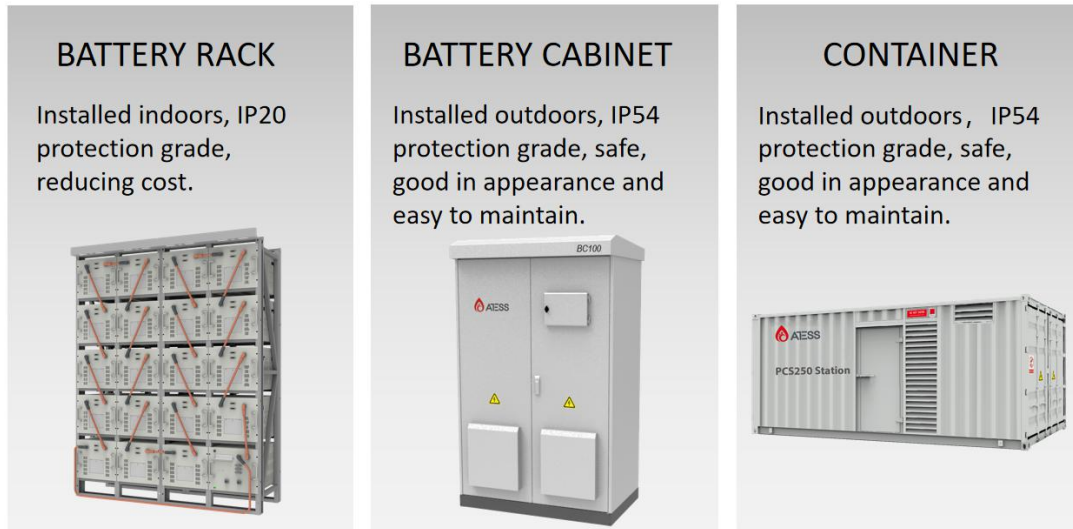

Fig.5-Installation layout solutions

3. ATESS BMS battery manager

Battery management system(BMS), the brain of a battery storage system, is a real-time monitoring system that can effectively monitor the battery voltage, current, cluster insulation state, SOC, module and single unit state (voltage, current, temperature, SOC, etc.), manage the charging and discharging safety of battery cluster , alarm and deal with emergency protection for possible faults, optimize the operation of the battery module and battery cluster To ensure the safety.

We have developed our own BMS with below features which can improve the reliability of battery solutions:

- It can automatically monitor the voltage, internal resistance, terminal voltage, charging and discharging current and temperature of each single unit online;
- Be able to do battery performance analysis, judges battery performance in time, and provides comprehensive analysis alarm information;
- It integrates battery operation information collection, capacity diagnosis, charge discharge balance management, fault alarm and other functions;
- Compact and rational design, highly integrated, and each unit adopts isolation technology, with good insulation performance, high reliability and safety;
- Collect the voltage and temperature of each battery in real time with high sampling accuracy;
- With the function of battery capacity prediction and balanced maintenance;
- Support maximum 7-channel temperature acquisition;



- CAN communication is adopted between energy storage battery management module and energy storage system management unit
- Efficient communication between inverter and lithium battery
- The effective and practical BMS improves the safety, stability and service life of the battery

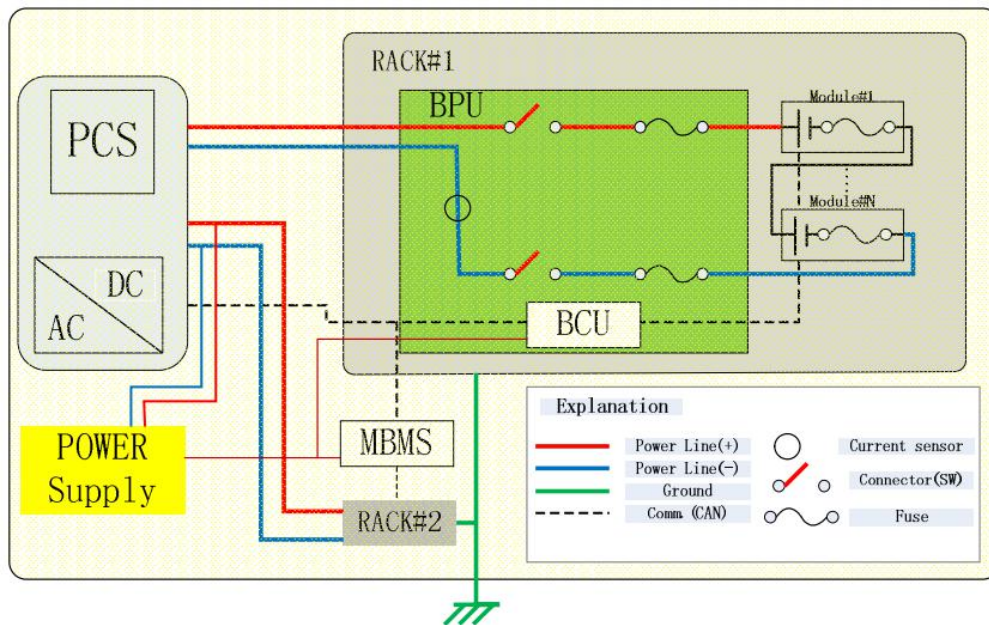

Fig.6-Diagram of three-level BMS

With all these years of experience and effort in storage system development, ATESS has not only won the recognition of customers in terms of reliability, efficiency and diversity of energy storage products, but also achieved excellent results in LFP battery performance.