

# PV-CB8M-P PV-CB16M-P

The PV combiner box is an accessory for multiple PV strings connections, and it is with a smart controller inbuilt for monitoring, along with comprehensive protections including the fuse and SPD.

## Features

-  Lightning protection
-  IP65 environment compatibility
-  RS485 communication interface
-  Monitoring function
-  Flexible design with 8 or 16 optional inputs
-  Input fuse for over current protection



## Block Diagram

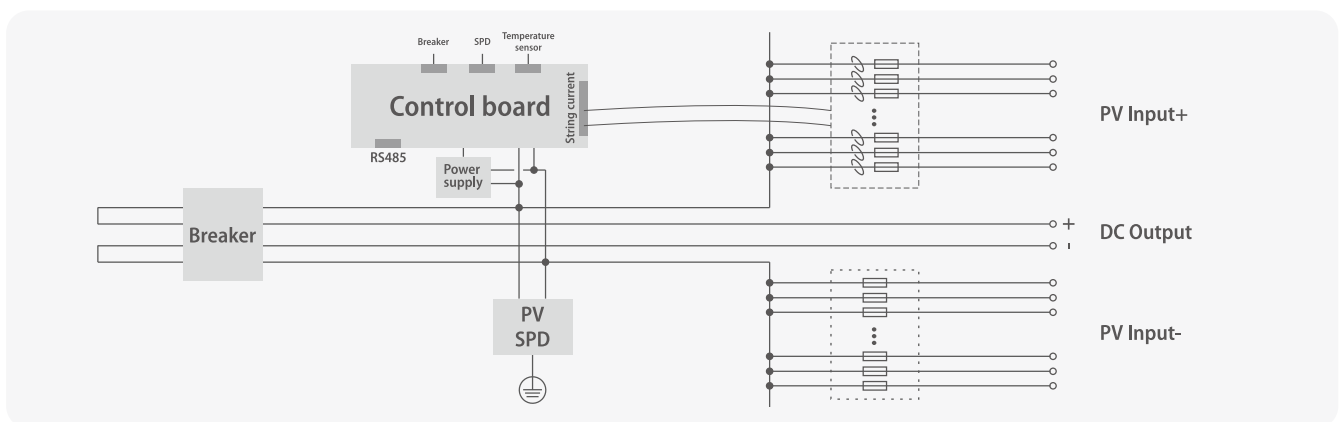

	PV-CB8M-P	PV-CB16M-P
<b>Input DC</b>		
Max. input voltage	1000V	1000V
Max. string Isc	20A	20A
Number of input string	8	16
Input fuse	1 on negative and positive pole of each string, 25A, 10*38mm	1 on negative and positive pole of each string, 25A, 10*38mm
Input cable gland	4mm-8mm cable diameter	4mm-8mm cable diameter
Input cable terminal	4mm <sup>2</sup> -6mm <sup>2</sup>	4mm <sup>2</sup> -6mm <sup>2</sup>

<b>Output DC</b>		
Number of output	1	1
Max. output current	160A	320A
Output breaker	200A	400A
Output cable terminal	70mm <sup>2</sup>	120mm <sup>2</sup>
Output cable gland	13mm-18mm cable diameter	18mm-25mm cable diameter

<b>General Information</b>		
Dimension (W/H/D)	600/500/172mm	600/500/202mm
Weight	22.5kg	29kg
Enclosure material	Galvanized steel	Galvanized steel
Protection degree	IP65	IP65
Operating temperature	-25°C~55°C	-25°C~55°C
Humidity	0~99%	0~99%
Altitude	2000m without derating	2000m without derating
Lightning protection	Type II	Type II
Cooling method	Natural convection	Natural convection
Mounting	Wall-mount	Wall-mount
Monitoring	String current, bus voltage, breaker status, surge arrester status, internal temperature	String current, bus voltage, breaker status, surge arrester status, internal temperature
Power supply	DC300V~1000V	DC300V~1000V
Power consumption	14W	14W
Communication	RS485	RS485